

MODEL VB

Beveled Ends

DESCRIPTION AND GENERAL PERFORMANCE SPECIFICATIONS

The V-Cone® flowmeter is a patented, differential pressure type flow measurement device. A cone is positioned in the center of the pipe to increase the velocity of the flowing fluid and create a differential pressure. This pressure difference can be measured and used to accurately interpret flowrate. Two taps are provided on every V-Cone to allow sensing of the high and low pressures. A typical V-Cone application can follow these general performance specifications:

- Accuracy: up to ±0.5% of rate
- Repeatability: ±0.1%
- Turndown: 10:1
- Standard Betas: 0.45 through 0.85
- Headloss: Percentage of differential pressure produced varies with beta ratio.
- Installation: Typically 0-3 diameters upstream and 0-1 diameters downstream.



The V-Cone is manufactured under a quality management system that is certified to ISO 9001:2008.

* Each V-Cone is sized for the intended application. Specific performance ratings must be obtained through the sizing process.

MODEL VB DIMENSIONS

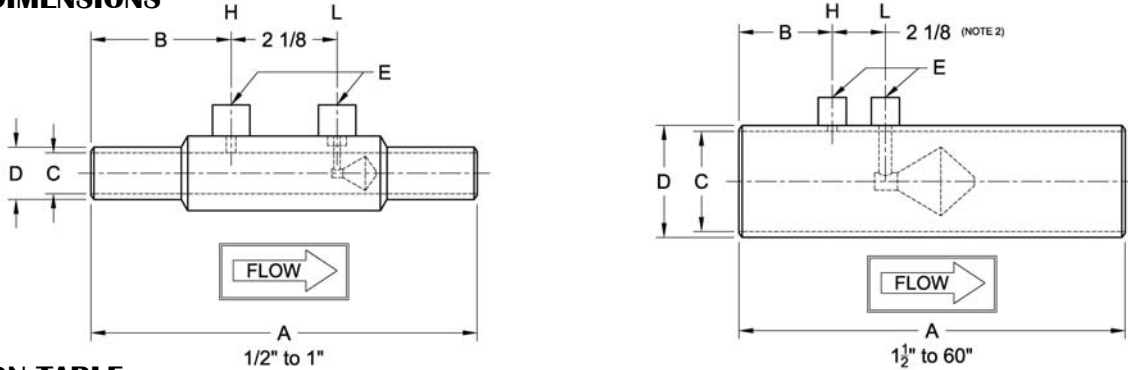

DIMENSION TABLE

Size	A (Note1)		B		C - Stainless (Note 2)		C - carbon (Note 2)		D		E (Note 2)
	inch	mm	inch	mm	inch	mm	inch	mm	inch	mm	NPT
1/2	7.75	197	2.81	71.4	0.622	15.8	-	-	0.84	21.3	1/4
3/4	7.75	197	2.81	71.4	0.824	20.9	-	-	1.05	26.7	1/4
1	7.75	197	2.81	71.4	1.049	26.64	-	-	1.315	33.4	1/4
1 1/2	9.75	248	2.88	73.2	1.645	41.78	-	-	1.9	48.3	1/4
2	11.63	295	3.31	84.1	2.104	53.44	-	-	2.375	60.3	1/2
2 1/2	11.50	292	3.25	82.6	2.504	63.60	-	-	2.875	73.0	1/2
3	13.50	343	3.25	82.6	3.104	78.84	-	-	3.5	88.9	1/2
4	15.50	394	3.75	95.3	4.090	103.8	-	-	4.5	114	1/2
6	21.50	546	4.00	102	6.065	154.1	6.065	154.1	6.625	168	1/2
8	25.25	641	4.63	118	7.981	202.7	7.981	202.7	8.625	219	1/2
10	27.25	692	4.63	118	10.02	254.5	10.02	254.5	10.75	273	1/2
12	29.25	743	4.88	124	12.00	304.8	11.94	303.3	12.75	323	1/2
14	29	737	5.5	140	13.25	336.6	13.13	333.5	14	355	1/2
16	29	737	5.5	140	15.25	387.4	15.00	381.0	16	406	1/2
18	31	787	5.5	140	17.25	438.2	17.25	438.2	18	457	1/2
20	35	889	5.5	140	19.25	489.0	19.25	489.0	20	508	1/2
24	47	1194	9.5	241	23.25	590.6	23.25	590.6	24	609	1/2
30	59	1500	9.5	241	29.25	743.0	29.25	743.0	30	762	1/2
36	61	1550	9.5	241	35.25	895.4	35.25	895.4	36	914	1/2
48	77	1956	11.5	292	47.25	1200	47.25	1200	48	1219	1/2
60	83	2108	11.5	292	59.25	1505	59.25	1505	60	1524	1/2

1. Overall length (A) tolerance varies with line size: 1/2" to 1", ±0.01" (±0.3mm); 1 1/2" to 4", ±0.06" (±2mm); 6" to 10", ±0.12" (±4mm); 12" to 24", ±0.19" (±6mm); 28" to 60", ±0.25" (±7mm).
2. Typical values shown.
3. Wall pressure ports are required for vertical up flow applications.



CONFIGURATION SHEET

MODEL NUMBER CONFIGURATION VB

Type	Size	Materials‡		Pipe Schedule	End Connections	Fittings
VB						
0A	½"	Q	S304	A	10	01 Beveled
0B	¾"	L	S304L	B	20	
01	1"	A	S316L	D	Std	N NPT
0C	1½"	S	CS Tube	E	40	S Socket
02	2"		S304 Cone, Support, & Couplings	F	80	Several types of fittings
0D	2½"	Epoxy Coated Blue (excluding cone)	J	100		
03	3"	U	CS Tube	K	120	
04	4"		S304 Cone, Support, & Couplings	L	140	
06	6"	Coating / Painting Per Customer Req.	G	160	‡Other materials can include:	
08	8"		H	XXS	HASTELLOY C-276	S321H
10	10"		M	10S	DUPLEX 2205	INCONEL 625
12	12"		P	XS	CHROMEMOLY P22/P11	
14	14"				MONEL K400/K500	
16	16"				CARBON STEELS	
18	18"				A350, A333, API5L, A106B	
20	20"					
24	24"					
30	30"					
36	36"					
48	48"					
60	60"					

Example: VB48UD01N V-Cone 48 inch line size, CS, schedule std pipe, beveled ends, ½" NPT fittings, coated or painted as required

STANDARD PIPE SCHEDULES

Stainless Steel		Carbon Steel	
Size	Std.	Size	Std.
½" to 10"	E	6" to 16"	E
12" and up	D	18" and up	D

Meters 6" and smaller utilize seamless pipe.
Meters 8" and larger utilize welded pipe.

ABBREVIATIONS

ASME	American Society of Mechanical Engineers
NPT	National pipe taper
SS	Stainless steel
CS	Carbon steel

Technical questions can be answered through a local representative or through our application engineers.

MANUFACTURING STANDARDS

McCrometer's welders and welding procedures are qualified in accordance with ASME Section IX. All meters are visually inspected for weld defects. Specific customer requirements can be complied with upon request.

The welding can be in accordance with:

- ASME Section VIII
- ASME B31.1
- ASME B31.3

Non-destructive testing can include:

- Hydrostatic Pressure Testing
- Penetrant Examination
- Radiographic Examination
- Positive Material Inspection
- Magnetic Particle Examination

REPRESENTED BY:

